

# HWJ-110U Exploded View

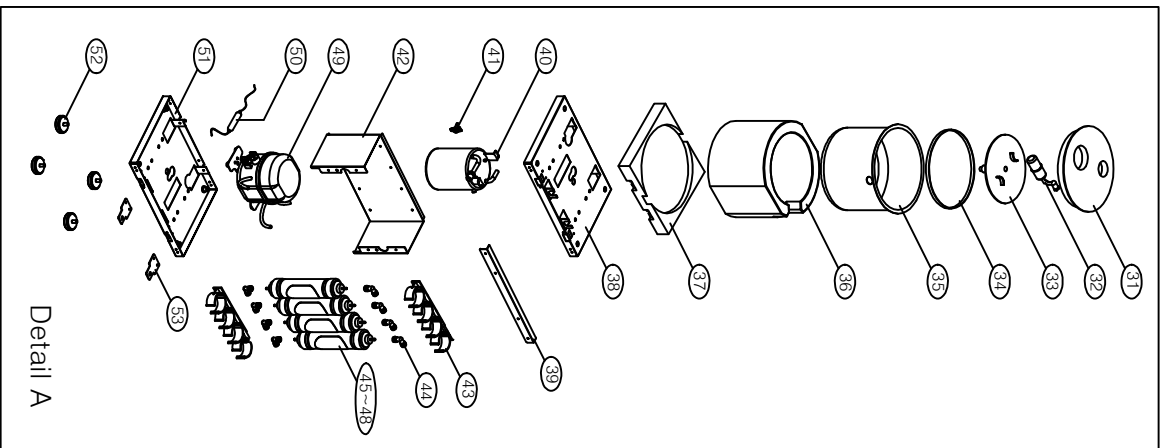

Detail A

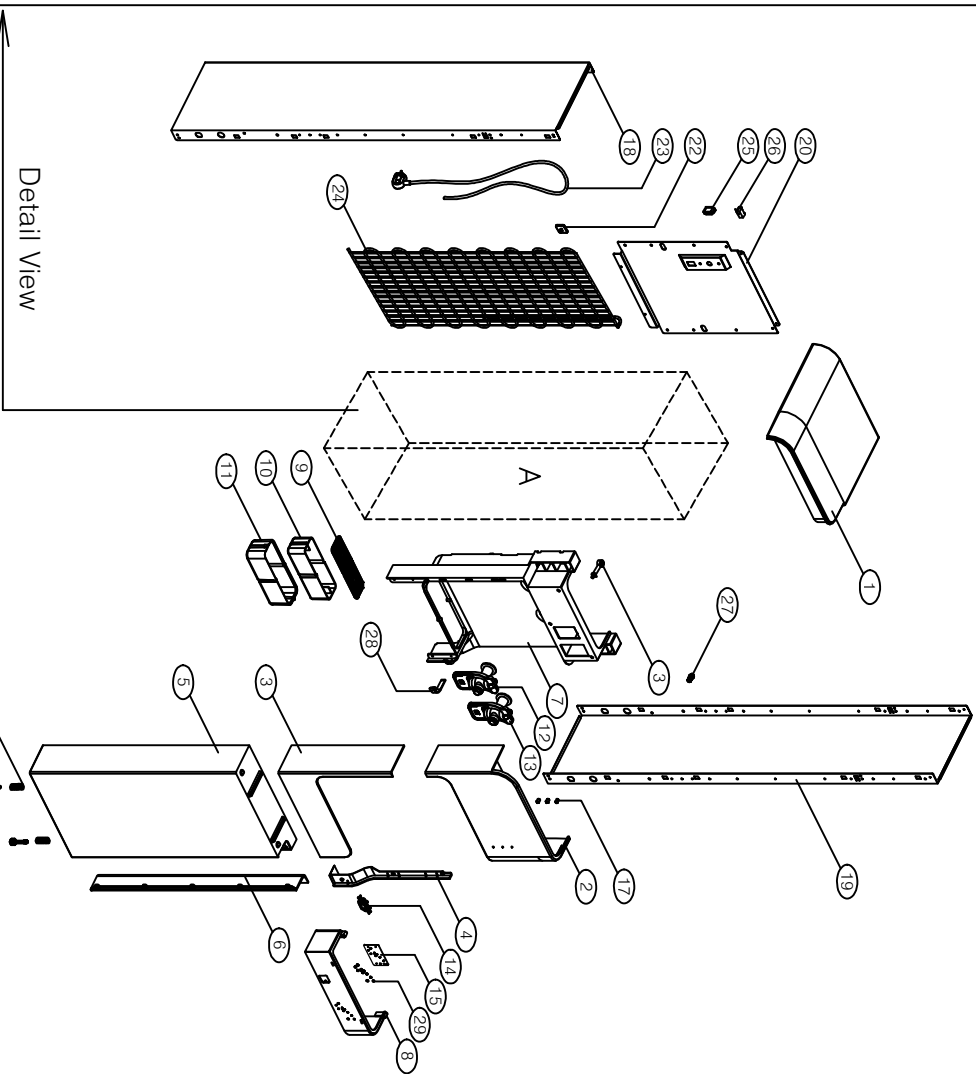

Detail View

1	Top Cover (S)
2	Upper Cover
3	Middle Cover
4	Middle Cover-Side
5	Lower Cover
6	Lower Cover-Side
7	Front Cover Base
8	Water Tap Cover
9	Water Tray Grill
10	Water Tray
11	Water Tray Base
12	Faucet(HOT)
13	Faucet(COLD)
14	Hot Water Button
15	Cubic Panel
16	Locking Pin
17	LED Cover
18	Side Panel-Left
19	Side Panel-Right
20	Back Panel
21	Bulk Head
22	Drain Valve
23	Power Cord
24	Wire Condensor
25	Hot Switch
26	Cold Thermostat
27	Water Outlet
28	Point Band
29	Swarovski Jewelry
30	Locking Spring
31	Cold Tank Cover
32	Float
33	Separate Plate
34	Ring Packing
35	Cold Tank
36	Cold Tank Lagging(R)
37	Cold Tank Lagging(S)
38	Middle Shelf
39	Joint Bracket
40	Hot Tank
41	Bimetal
42	Filter Bracket
43	Filter Clip
44	L Fitting
45	Sediment Filter
46	Pre Carbon Filter
47	UF Membrane Filter
48	Post Carbon Filter
49	Compressor
50	Dryer
51	Bottom Panel
52	Control Wheels
53	Locking Bracket