

BRAND K
KOREAN NATIONAL
CO-BRAND

EOS

Air Purification System



Model : EOS-501D / 501E
USER'S MANUAL



WACO Corp.

MADE IN KOREA 

A-301, Hage Technotown, 10,
Nowon-ro 15-gil, Nowon-gu, Seoul, Korea
TEL +82-2-948-0657
FAX +82-2-948-2342
www.waco-corp.com



WACO Corp.

MADE IN KOREA 

Thank you very much for selecting WACO Corp.
In order to bring the best use of your system, please read the
user's manual carefully before installation and follow the regulations.

Strong Point of Product

1. Maximization of filter area and Superiority of Collection Efficiency

Purification ability of filter was maximized by adopting filters of 3stages (Pre filter, Multifunctional Deodorization filter, Fine dust filter) through upper, Left and Right's side. These filters eliminate Fine particulate and prevent breeding of Microbial, mold. The collection efficiency for more than 0.3 μ m. Fine dust is over 99.97% and the elimination efficiency for odor is over 90%.



4. Generation of Ion Cluster

It can maintain fresh air by the generator of ion cluster on the upper part. (not emission of Ozone)

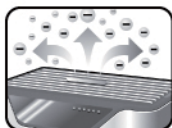

5. Emission of an Incense

Aroma materials case on the upper side is emitted according to taste of consumers and the amount of emission can be controlled.



2. Realization of the best performance of the in the world by strong purification ability.

The air purification ability (CADR) of the top in the world was realized more than 450 through inhale of polluted air by 5 sides and exhaust of purified air by 3 sides.



3. The measurement of pollution level

The pollution level is checked with the naked eye through pollution sensor.



6. Re-using of filter

The Prefilter is designed as washable filter so that the consumer can maintain the filter's function by cleaning.



7. Convenience of moving

Unit is designed as it can be freely moved room to room and room to floor by using of caster.

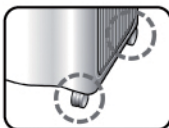

Table of Contents

Contents

Precautions in Safety	-----	2
Indicators for each category	-----	4
Air circulation channel	-----	4
Name and resolution of filter	-----	5
Separation method of filter's box	-----	5
Name of each part	-----	6
Check point before using	-----	7
Operation	-----	8
How to clean and main the air purifier	-----	11
METHOD OF GEL	-----	12
Checking points before reporting of trouble shooting	-----	12
Specification	-----	13
Product warranty card	-----	14

PRECAUTIONS IN SAFETY

Please use product rightly after reading contents well for safety of users



INSTALLATION



PRECAUTION

- Please do not place an obstacle in inlet or outlet of product.**
 - It may cause malfunction and air purification efficiency may fall.
- Please install a product at the place where is far more than 10cm from nearby.**
 - The purification ability may fall in case inhale area of air is narrowed from space.

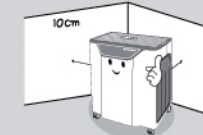

PROHIBITION

- Please install the product after avoiding direct light, heating appliances, especially moisture.**
 - Performance of product is fallen and it may malfunction.



POWER SUPPLY



PROHIBITION

- Please do not unplug a electric wire and touch plug by wet hands.**
 - It may cause electric shock and fire.



- Please do not use injured power cord, plug, loose-fitting outlet.**
 - It may cause electric shock and fire.

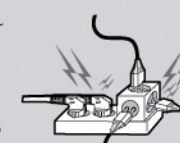

PRECAUTION

- Please contact a service center after putting off a power supply in case strange noise and burning smell, smoke may caused from product.**
 - It may cause electric shock, fire seriously.
- Please unplug if you do not use for a long time.**
 - The un-needed electric power is exhausted and may cause a short circuit, fire.

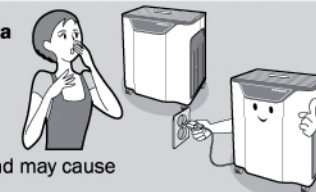

DURING USING



PROHIBITION

- Please do not insert a finger, other materials in inlet or outlet on product.**
 - It may cause malfunction and electric shock, fire.
- Please do not give over-loaded impact on product artificially.**
 - It may cause malfunction, fire.



- Please do not open filter box during operation.**
 - It may cause mal function, accident.
 - Do not insert a pen, finger, other materials in inlet during operation.
 - It is cause to damage of product and malfunction



PRECAUTIONS IN SAFETY

Please use product rightly after reading contents well for safety of users



DURING USING



PROHIBITION

Please be sure to ventilate occasionally in case it is used together with combustion appliances in closing inner area.



PRECAUTION

Please use after inserting filter essentially.

■ The purification ability will be fallen if it is operated without filter.



PROHIBITION OF DISASSEMBLE

Please do not resolve and repair, reconstruct a product.

■ It may cause malfunction and electric shock, fire. please contact a service center if product is needed to repair.



OTHERS



PRECAUTION

Please start a cleaning, repair in case a power supply is putted off and turning of fan is stopped.

■ It may cause electric shock, other danger.

Please do not clean through using of chemicals, Alcohols etc.

■ It may cause electric shock, fire.
■ The out side of product can be transformed.



PROHIBITION

Please be sure not touch direct light in case filter is dried after washing.

■ The filter has a possibility of transformation. Please use filter after drying 5 hours in shade.

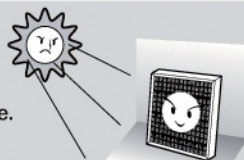

Pre-cautions

- 1) The system shall be operated after its user manual is known well by users.
- 2) If disable people or unexperienced people use the system, the system shall be used under the control of the experienced people or it shall not be used.
- 3) Children need to be controlled not to use the system as toys.

Attention : In case of damage of power cords, please do not repair or remodel the system, and please call to your supplier or the manufacturer.

INDICATOR OF EACH CATEGORY / AIR CIRCULATION CHANNEL

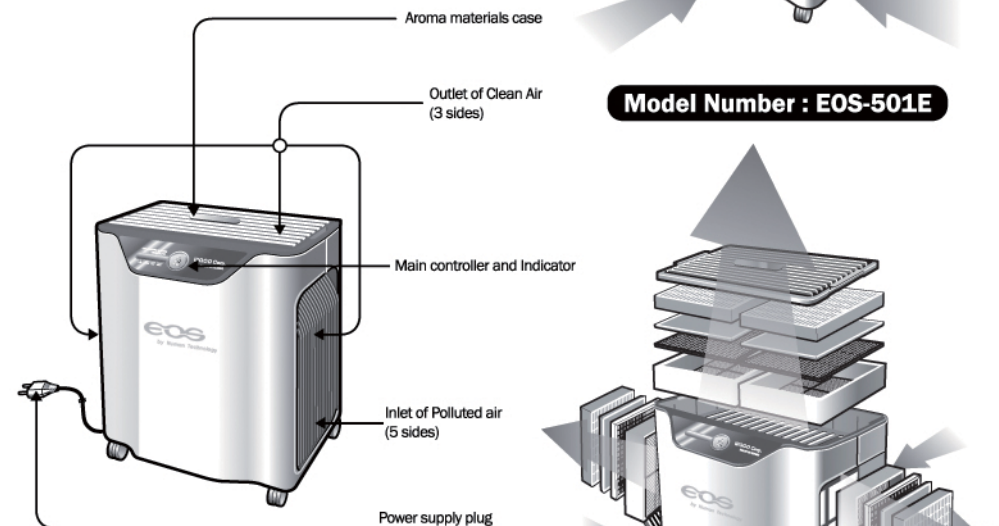
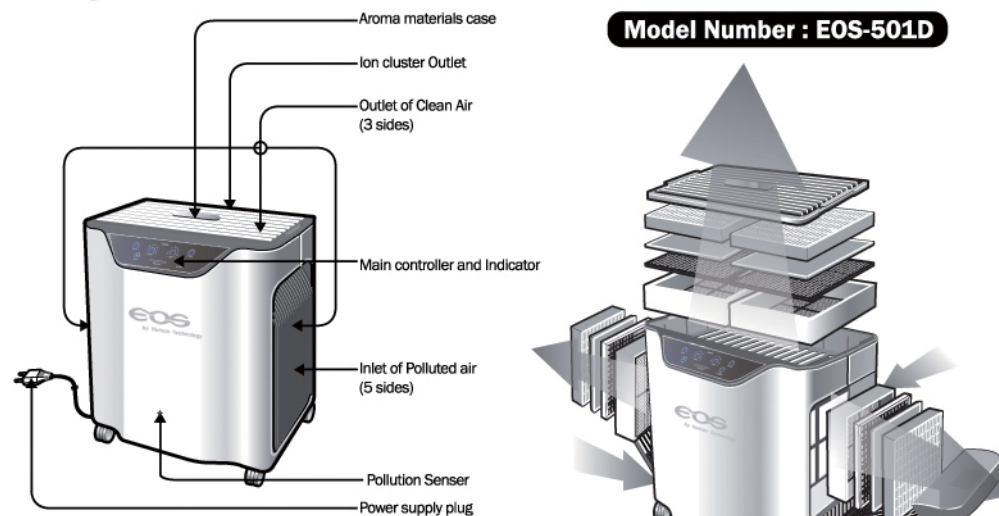

NAME AND RESOLUTION OF FILTER / SEPARATION METHOD OF FILTER'S BOX (Model 501D, 501E)

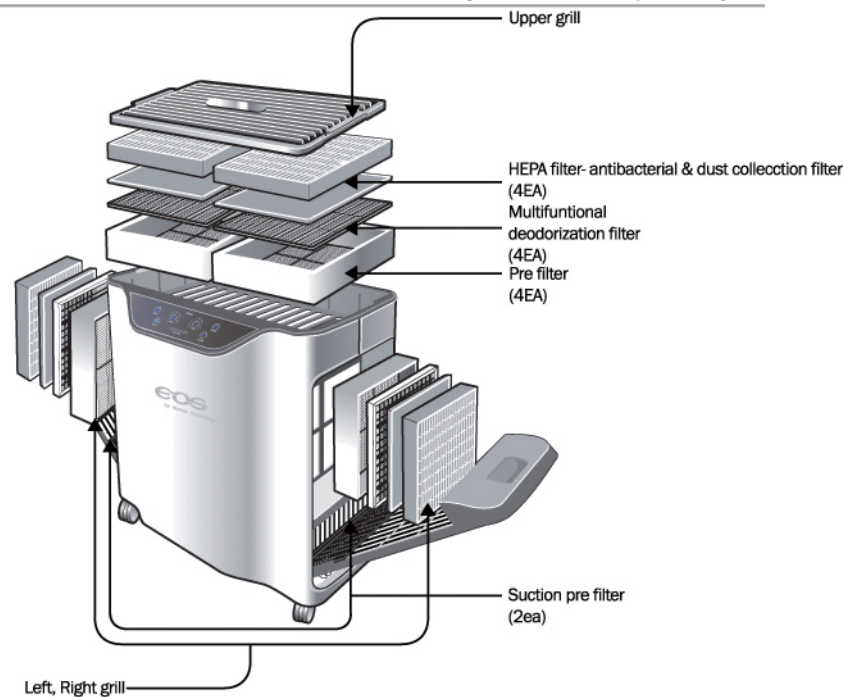

HOW TO SEPARATE UPPER-FILTER

Please draw up upper grill through a handle and take out inner filter box and then separate each filter.

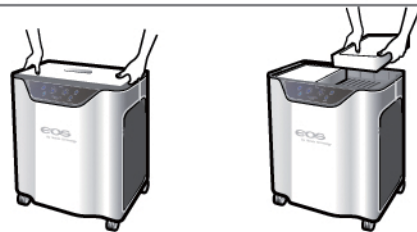

HOW TO SEPARATE FILTER OF LEFT, RIGHT SIDE.

Please open filter box to the body side after grasping grill handle of left, right side and then take out inner filter box and separate each filter.



NAME OF EACH PART

MAIN CONTROLLER AND INDICATOR / EXPLANATION FOR BUTTON (EOS-501D)

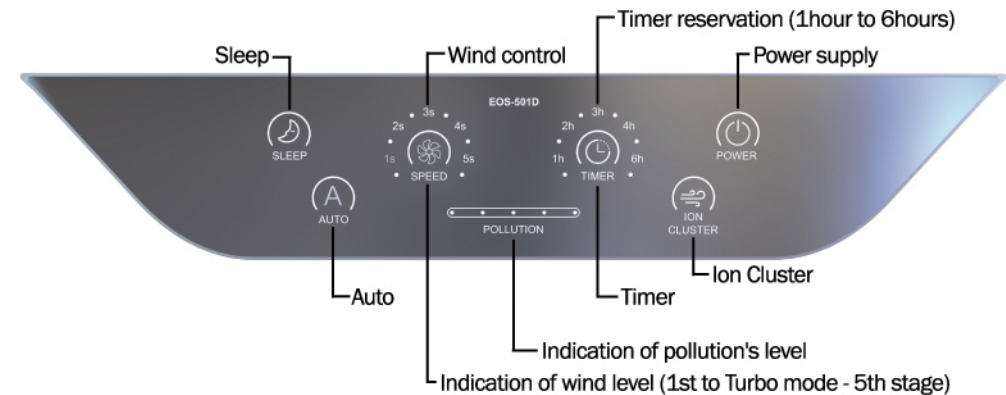

In case power supply is on, operation is stated from auto-operation mode. If you press POWER key again, it will be off.



Wind is controlled from 1st to Turbo mode (5th stage) through SPEED key and you can select wind level according to space.



In case the TIMER key is operated, it is operated by fixing mode of reserved time. The time is fixed from 1hour to 6hours whenever you press the TIMER key.



In case the AUTO key is selected, the pollution level of inner air is automatically sensed by pollution sensor so that it can control and operate the FAN's speed.



In case the SLEEP key is operated, the speed level is changed to Level 1 and the LED light changes little dark.



When you press the ION CLUSTER key, the function of ion cluster is activated and the LED light is turned on. If you press the key, it will be inactivated and the LED light out.

NAME OF EACH PART / CHECK POINT BEFORE USING

MAIN CONTROLLER AND INDICATOR / EXPLANATION FOR BUTTON (EOS-501E)



In case power supply / WIND CONTROL is on, operation is started from LOW->MEDIUM->HIGH->TURBO->OFF according to press the function key.

*The operation is stopped in case of press the function keys for 2 seconds regardless wind stage.

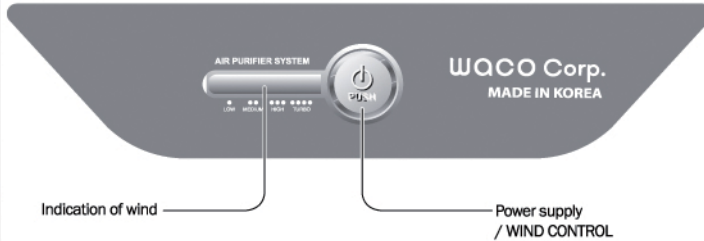

REMOTE CONTROL (Model : EOS-501D)

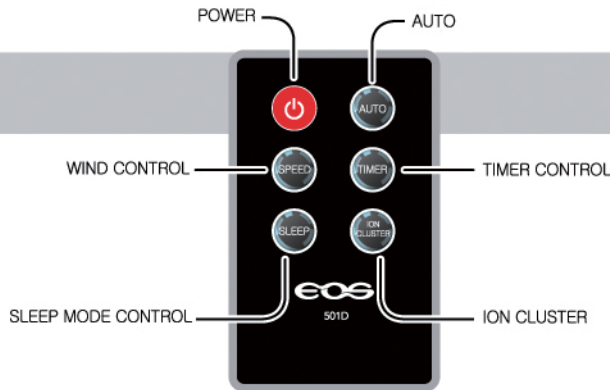

CHECK INSTALLATION

Please check the following conditions for installation.

- Flat place where is not inclined.
- The place where has not interrupted inlet and outlet of Air.
- The place where has not moisture and inflammable.
- The place where is not interrupted for passing.
- The near place from an electric outlet.



OPERATION (Model : EOS-501D)

AUTO OPERATION

When you want to control purified level according to pollution situation of air.



THE OPERATION CONDITION IN CASE OF AUTO OPERATION

☞ PURITY DEGREE

- The optimum purification condition is selected according to Pollution level of inner air and then need not to control separately.
- In case you control the purity degree, the Auto operation is cancelled and is operated according to the selected purity degree.

IN CASE AIR CLEANER IS NOT OPERATED



Please press the POWER and start operation.

- The sound is changed and then auto operation is started.

IN CASE AIR CLEANER IS OPERATED



Please press the AUTO key for the Auto Operation.

- Whenever you press the AUTO key, it is selected the alternate Auto and Manual operation.

MANUAL OPERATION-1

When you want to control dust which was entered into indoors.



PLEASE PRESS POWER KEY AND START OPERATION



- While the sound is changed, the air purifier is turned on and then auto operation is started.

PLEASE PRESS AUTO KEY FOR THE MANUAL OPERATION



- Whenever you press AUTO key, it is selected the alternate Auto and Manual operation. Please press and select the AUTO key until the time of indication for Manual operation.

THE OPERATION CONDITION IN CASE OF MANUAL OPERATION

☞ PURITY DEGREE

- You can control Purity degree directly.
- In case you control auto operation, the manual operation is cancelled and is automatically operated according to pollution degree.

OPERATION (Model : EOS-501D)

CONTROL OF PURITY DEGREE When you want to freely control the condition of purified wind.



CONTROL METHOD OF PURITY DEGREE



Please press SPEED for selecting your desired Purity degree.

- The repeated operation is selected from 1 to turbo(5 stages) whenever you press the fuction key (SPEED).
- Please press the fuction key and select until the time of indication for your desired Purity degree.

THE OPERATION CONDITION IN CASE OF CONTROL OF PURITY DEGREE.

PURITY DEGREE

- It is operated by selected purity degree.
- In case [AUTO] fuction key is selected, the selected purity degree is cancelled and the air purifier is automatically operating.

TIMER OPERATION

You can operate according to appointed time.



PLEASE PRESS POWER KEY FOR STARTING OPERATION.



- While the sound is changed, the air purifier is turned on and then auto operation is started.

PLEASE PRESS TIMER KEY AND SELECT TIMER OPERATION.



- The setting time of reservation is from 1hour to 6hours and the reservation time is set per 1hour. Please press TIMER key repeatedly for cancelling the setting.

OPERATION (Model : EOS-501D)

FUNCTION FOR ION CLUSTER How to use the function for eliminating harmful matters?



PLEASE PRESS ION CLUSTER ON THE SCREEN



- ION CLUSTER : When ION CLUSTER is activated, it eliminates cigarette smoke, smell, stink where the system is being used. And it also removes mold, virus, bacteria and others in the air.

ABOUT ION CLUSTER

- Deodorization : The generated ion cluster surrounds smell and stink such as cigarette smoke and it behaves each other. And it changes water (H₂O) and carbon dioxide (CO₂) which are harmless for human bodies.

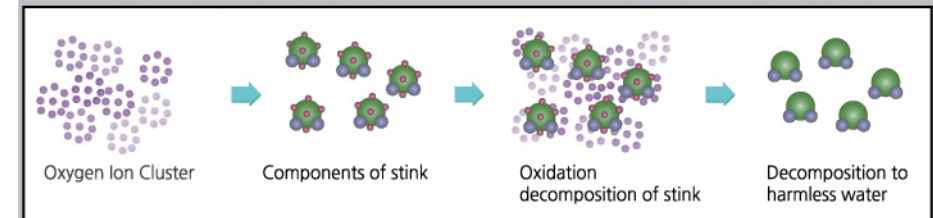

- Removal of microorganism : The generated ion cluster surrounds virus, bacteria, H1N1, mold and others, and it behaves each other. And it changes protein which is harmless for human bodies.

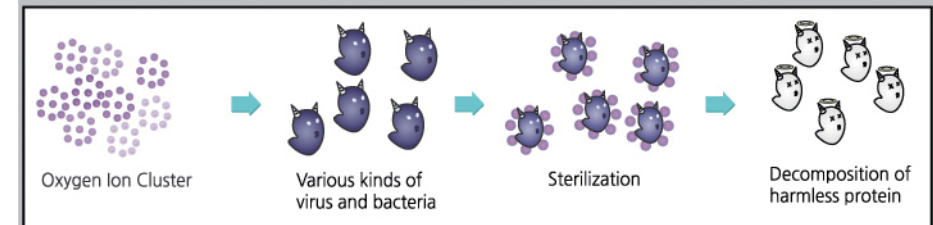

HOW TO CLEAN AND MAIN THE AIR PURIFIER

Please be sure to unplug when you clean the air purifier.

HOW TO CLEAN POLLUTION SENSOR(Model : EOS-501D)

The sensor is equipment which sensed pollution level. The efficiency can be maintained by cleaning the sensor regularly.



Please frequently clean the front of sensor under the condition which is full of dust because the trouble of capacity can be occurred in this condition.



HOW TO WASH THE WASHABLE FILTERS

The washable filters have a function of elimination for large dust or hair of an animal in air. Please wash the filters every three months or according to the condition of the filter on Main controller as following method.

- 1 Please pull the filter box after opening grill of left and right sides.
- 2 Please insert Gel and put in the case.



- 3 Please wash the Perfilter the with tepid water.

Please wash the net with a soft brush in tepid water which is added to a detergent.



- 4 In case of deodorization filter, brush off dust by once at 2 months.

In case there is dust on surface of deodorization filter, it may affect deodorization efficiency. In case of cleansing, it may stain you with black powder (activated carbon) but it is harmless to body.



PRECAUTION

Deodorization filter is not washable and it does not need to wash. However, In case it became moist, please dry it perfectly and then insert it into the main body. If you do not dry it perfectly and then insert it into the main body, it may cause damage of the collection filter and odor with wind.



Filters are made of prefilter, deodorization filter and collection filter.

REPLACING TIME FILTERS AND METHOD OF GEL

REPLACING TIME FILTER

FILTERS	REPLACING TIME
HEPA filter-antibacterial & dust collection filter	1 year or 1.5 years (Replacing time has a difference according to method place of operation)
Deodorization filter	6 Months (Replacing time has a difference according to method place of poeration)

METHOD OF GEL / CHECKING POINTS BEFORE REPORTING OF TROUBLE SHOOTING

METHOD OF GEL

- 1 Please cut the packing material.
- 2 Please insert Gel and put in the case.



- 3 Please combine the case with the cover of case on the Upper grill(Please combine with sound "Tak")



- 4 Please assemble on the upper grill.

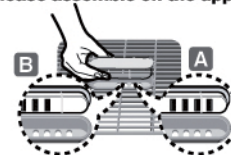

Concentration of Gel and using time are subject to change according assemble.

- A If hole of upper grill(4EA) are in high concentration of Gel.
- B If hole of upper grill(2EA) are in low concentration of Gel.

CHECKING POINTS BEFORE REPORTING OF TROUBLE SHOOTING

Please check before reporting of trouble shooting.

SYMPTOMS	CHECK POINT	SOLUTION
Unit does not work	Is there a stoppage of electric current?	Please check connection of electric current and operate again.
	Is Power supply plug connected?	Please set the power supply and operate again.
	Is an electric outlet faulty?	Please operate with another electric outlet.
The strange smell is coming out	Do you use unit at the place where is full of odor or smoke?	The efficiency of cleaning air can be fallen at the place where is full of smoke or odor. Please use the air purifier after ventilating air.
	Is the washable filters unclean?	Please clean washable filters.

SPECIFICATION

Model Name	EOS-501D / EOS-501E
Power Supply	AC220-240V , 50/60Hz
Using space	60m² (698 ft2) certificated by AHAM
Consumption Electricity	67W(MAX)
Electric current for Operation	0.8A(MAX)
Weight	14kg
Size(W × D × H)	530×670×360(mm)

•Design and Specification can be changed without a notice for improvement of quality.



PRODUCT WARRANTY CARD

We WACO Corp. supply the reliable products through the perfect quality control and service inspection considering Air and environment based on the views of our clients, and do our best to fulfill customer satisfaction.

We guarantee that the repair or exchange of faulty components will be conducted without charge when the defect occurred during the manufacturing process or malfunction occurred within the guarantee period. Please refer to your local distributor in such case.

Guarantee Period

- 1. Warranty period is for 12 months after purchase of the product.**
- 2. However in cases mentioned below, charges would be applicable.**
 - 1) After expiry of free warranty period.**
 - 2) Damage or malfunction caused by careless usage.**
 - 3) Malfunction occurred due to natural calamity.**
 - 4) Loss of the warranty caed.**

Repair Date	Repair Contents	Repair Place	Name of Repair Place